**Qualification test of welders — Fusion
welding —**

**Part 2:
Aluminium and aluminium alloys**

*Épreuve de qualification des soudeurs — Soudage par fusion —
Partie 2: Aluminium et alliages d'aluminium*



Reference number
ISO 9606-2:2004(E)

© ISO 2004

PDF disclaimer

This PDF file may contain embedded typefaces. In accordance with Adobe's licensing policy, this file may be printed or viewed but shall not be edited unless the typefaces which are embedded are licensed to and installed on the computer performing the editing. In downloading this file, parties accept therein the responsibility of not infringing Adobe's licensing policy. The ISO Central Secretariat accepts no liability in this area.

Adobe is a trademark of Adobe Systems Incorporated.

Details of the software products used to create this PDF file can be found in the General Info relative to the file; the PDF-creation parameters were optimized for printing. Every care has been taken to ensure that the file is suitable for use by ISO member bodies. In the unlikely event that a problem relating to it is found, please inform the Central Secretariat at the address given below.

© ISO 2004

All rights reserved. Unless otherwise specified, no part of this publication may be reproduced or utilized in any form or by any means, electronic or mechanical, including photocopying and microfilm, without permission in writing from either ISO at the address below or ISO's member body in the country of the requester.

ISO copyright office
Case postale 56 • CH-1211 Geneva 20
Tel. + 41 22 749 01 11
Fax + 41 22 749 09 47
E-mail copyright@iso.org
Web www.iso.org

Published in Switzerland

Foreword

ISO (the International Organization for Standardization) is a worldwide federation of national standards bodies (ISO member bodies). The work of preparing International Standards is normally carried out through ISO technical committees. Each member body interested in a subject for which a technical committee has been established has the right to be represented on that committee. International organizations, governmental and non-governmental, in liaison with ISO, also take part in the work. ISO collaborates closely with the International Electrotechnical Commission (IEC) on all matters of electrotechnical standardization.

International Standards are drafted in accordance with the rules given in the ISO/IEC Directives, Part 2.

The main task of technical committees is to prepare International Standards. Draft International Standards adopted by the technical committees are circulated to the member bodies for voting. Publication as an International Standard requires approval by at least 75 % of the member bodies casting a vote.

Attention is drawn to the possibility that some of the elements of this document may be the subject of patent rights. ISO shall not be held responsible for identifying any or all such patent rights.

ISO 9606-2 was prepared by the European Committee for Standardization (CEN) in collaboration with Technical Committee ISO/TC 44, *Welding and allied processes*, Subcommittee SC 11, *Qualification requirements for welding and allied processes personnel*, in accordance with the Agreement on technical cooperation between ISO and CEN (Vienna Agreement).

Throughout the text of this document, read “...this European Standard...” to mean “...this International Standard...”.

This second edition cancels and replaces the first edition (ISO 9606-2:1994) which has been technically revised. It also incorporates ISO 9606-2:1994/Amd.1:1998.

ISO 9606 consists of the following parts, under the general title *Qualification test of welders — Fusion welding*:

- *Part 1: Steels*
- *Part 2: Aluminium and aluminium alloys*
- *Part 3: Copper and copper alloys*
- *Part 4: Nickel and nickel alloys*
- *Part 5: Titanium and titanium alloys, zirconium and zirconium alloys*

Annex ZA provides a list of corresponding International and European Standards for which equivalents are not given in the text.

For the purposes of this part of ISO 9606, the CEN annex regarding fulfilment of European Council Directives has been removed.

Contents

	page
Foreword.....	v
Introduction	vi
1 Scope	1
2 Normative references	1
3 Terms and definitions	2
4 Symbols and abbreviated terms	2
4.1 General.....	2
4.2 Reference numbers of welding processes	2
4.3 Abbreviations	3
5 Essential variables and range of qualification	3
5.1 General.....	3
5.2 Welding processes	4
5.3 Product type.....	5
5.4 Type of weld	6
5.5 Material groups	6
5.6 Welding consumables.....	7
5.7 Dimensions.....	7
5.8 Welding positions	8
5.9 Weld details	9
6 Examination and testing	10
6.1 Supervision	10
6.2 Shapes, dimensions and numbers of test pieces	10
6.3 Welding conditions.....	14
6.4 Test methods.....	15
6.5 Test piece and test specimen.....	15
6.6 Test record	20
7 Acceptance requirements for test pieces	20
8 Re-tests.....	21
9 Period of validity	21
9.1 Initial qualification	21
9.2 Confirmation of the validity	21
9.3 Prolongation of qualification	21
10 Certificate	21
11 Designation	22
Annex A (informative) Welder's qualification test certificate.....	23
Annex B (informative) Designation examples	24
Annex C (informative) Job knowledge	28
Annex D (informative) Variables to be confirmed and traceable for prolongation.....	31
Annex ZA (normative) Normative references to International publications with their corresponding European publications	32
Bibliography	33

Foreword

This document (EN ISO 9606-2:2004) has been prepared by Technical Committee CEN/TC 121 "Welding", the secretariat of which is held by DIN, in collaboration with Technical Committee ISO/TC 44 "Welding and allied processes".

This European Standard shall be given the status of a national standard, either by publication of an identical text or by endorsement, at the latest by June 2005, and conflicting national standards shall be withdrawn at the latest by June 2005.

This document has been prepared under a mandate given to CEN by the European Commission and the European Free Trade Association, and supports essential requirements of EU Directive(s).

For relationship with EU Directive(s), see informative Annex ZA, which is an integral part of this document.

This document supersedes EN 287-2:1992.

This series of standards consists of the following parts, under the general title *Qualification test of welders — Fusion welding*:

- EN 287-1: Steels
- EN ISO 9606-2: Aluminium and aluminium alloys
- EN ISO 9606-3: Copper and copper alloys¹⁾
- EN ISO 9606-4: Nickel and nickel alloys¹⁾
- EN ISO 9606-5: Titanium and titanium alloys, zirconium and zirconium alloys¹⁾

According to the CEN/CENELEC Internal Regulations, the national standards organizations of the following countries are bound to implement this European Standard: Austria, Belgium, Cyprus, Czech Republic, Denmark, Estonia, Finland, France, Germany, Greece, Hungary, Iceland, Ireland, Italy, Latvia, Lithuania, Luxembourg, Malta, Netherlands, Norway, Poland, Portugal, Slovakia, Slovenia, Spain, Sweden, Switzerland and United Kingdom.

¹⁾ The general title of these document is *Approval testing of welders - Fusion welding*



Introduction

The ability of a welder to follow verbal or written instructions and verification of a welder's skills are important factors in ensuring the quality of the welded product.

The testing of a welder's skill in accordance with this document depends on welding techniques and conditions used in which uniform rules are complied with, and standard test pieces are used.

The principle of this document is that a qualification test qualifies the welder not only for the conditions used in the test, but also for all joints which are considered to weld easier on the presumption that the welder has received a particular training and/or has industrial practice within the range of qualification.

The qualification test can be used to qualify a welding procedure and a welder provided that all the relevant requirements, e.g. test piece dimensions, are satisfied (see EN ISO 15614-2).

Qualifications in accordance with EN 287-2 or ISO 9606-2 existing at the date of publication of this document are, at the end of their period of validity, to be interpreted in accordance with the requirements of this standard.

Requests for official interpretations of any aspect of this standard should be directed to the Secretariat of ISO/TC 44/SC 11 via your national standards body, a complete listing which can be found at www.iso.org.

1 Scope

This document specifies the requirements for qualification of welders for fusion welding of aluminium and aluminium alloys.

This document provides a set of technical rules for systematic qualification of welders which are independent of product type, location and examiner/examining body.

When qualifying welders, the emphasis is placed on the welder's ability to manually manipulate the welding torch and thereby produce a weld of acceptable quality.

The welding processes referred to in this document include those fusion welding processes which are designated as manual or partly mechanized welding. It does not qualify fully mechanized and automated welding processes (see EN 1418 or ISO 14732).

2 Normative references

The following referenced documents are indispensable for the application of this document. For dated references, only the edition cited applies. For undated references, the latest edition of the referenced document (including any amendments) applies.

EN 910, *Destructive tests on welds in metallic materials — Bend tests.*

EN 970, *Non-destructive examination of fusion welds — Visual examination.*

EN 1320, *Destructive tests on welds in metallic materials — Fracture test.*

EN 1321, *Destructive tests on welds in metallic materials — Macroscopic and microscopic examination of welds.*

EN 1418:1997, *Welding personnel — Approval testing of welding operators for fusion welding and resistance weld setters for fully mechanized and automatic welding of metallic materials.*

EN 1435, *Non-destructive examination of welds — Radiographic examination of welded joints.*

EN 30042, *Arc-welded joints in aluminium and its weldable alloys — Guidance on quality levels for imperfections (ISO 10042:1992).*

EN ISO 4063, *Welding and allied processes — Nomenclature of processes and reference numbers (ISO 4063:1998).*

EN ISO 6947, *Welds — Working positions — Definitions of angles of slope and rotation (ISO 6947:1993).*

EN ISO 15607:2003, *Specification and qualification of welding procedures for metallic materials — General rules (ISO 15607:2003).*

EN ISO 15609-1:2004, *Specification and qualification of welding procedures for metallic materials — Welding procedure specification — Part 1: Arc welding (ISO 15609-1:2004).*

EN ISO 15614-2, *Specification and qualification of welding procedures for metallic materials — Welding procedure test — Part 2: Arc welding of aluminium and its alloys (ISO 15614-2:2004).*

ISO 857-1, *Welding and allied processes — Vocabulary — Part 1: Metal welding processes.*

NOTE A list of ISO Standards conforming to these EN Standards is given in Annex ZB.

3 Terms and definitions

For the purposes of this document, the terms and definitions given in EN ISO 15607:2003 and EN 1418:1997 and the following apply.

3.1

welder

person who holds and manipulates the electrode holder, welding torch or blowpipe by hand

3.2

examiner

person who has been appointed to verify compliance with the applicable standard

NOTE In certain cases, an external independent examiner may be required.

3.3

examining body

organization that has been appointed to verify compliance with the applicable standard

NOTE In certain cases, an external independent examining body may be required.

3.4

backing

material placed at the reverse side of a joint preparation for the purpose of supporting molten weld metal

3.5

root run

in multi layer welding, the run(s) of the first layer deposited in the root

3.6

filling run

in multi layer welding, the run(s) deposited after the root run(s) and before the capping run(s)

3.7

capping run

in multi layer welding, the run(s) visible on the weld face(s) after completion of welding

3.8

weld metal thickness

thickness of the weld metal excluding any reinforcement

4 Symbols and abbreviated terms

4.1 General

Where the full wording is not used, the following abbreviations and reference numbers shall be used when completing the welder's qualification test certificate (see Annex A).

4.2 Reference numbers of welding processes

This document qualifies the following manual or partly mechanized welding processes (reference numbers of welding processes for symbolic representation are listed in EN ISO 4063):

- 131 metal inert gas welding (MIG welding);
- 141 tungsten inert gas arc welding (TIG welding);
- 15 plasma arc welding.

NOTE The principles of this document may be applied to other fusion welding processes.

4.3 Abbreviations

4.3.1 For test pieces

<i>a</i>	design throat thickness
BW	butt weld
<i>D</i>	outside pipe diameter
FW	fillet weld
<i>l</i> ₁	length of test piece
<i>l</i> ₂	half width of test piece
<i>l</i> _f	examination length
P	plate ²⁾
<i>s</i>	weld metal thickness for butt welds only (plate thickness or pipe wall thickness for single process)
<i>s</i> ₁	weld metal thickness for welding process 1
<i>s</i> ₂	weld metal thickness for welding process 2
<i>t</i>	material thickness of test piece (plate or wall thickness)
<i>t</i> ₁	material thickness of test piece for welding process 1
<i>t</i> ₂	material thickness of test piece for welding process 2
T	pipe ³⁾
<i>z</i>	leg length of fillet weld.

4.3.2 For welding consumables

nm	no filler metal
S	solid wire/rod

4.3.3 For other weld details

bs	welding from both sides
mb	welding with backing
ml	multi layer
nb	welding without backing
sl	single layer
ss	single-side welding

5 Essential variables and range of qualification

5.1 General

The qualification of welders is based on essential variables. For each essential variable a range of qualification is defined. All test pieces shall be welded using the essential variables independently, except for 5.7 and 5.8. If the welder has to weld outside the range of qualification a new qualification test is required. The essential variables are:

- a) welding processes;
- b) product type (plate and pipe);
- c) type of weld (butt and fillet);
- d) material groups;

-
- 2) The word "plate" alone or in combination is used to mean "wrought plate" and "flat extruded bars".
 - 3) The word "pipe" alone or in combination, is used to mean "pipe", "tube" or "hollow section".

- e) welding consumables;
- f) dimensions (material thickness and outside pipe diameter);
- g) welding positions;
- h) weld details (backing, single side welding, both side welding, single layer, multi layer).

5.2 Welding processes

Welding processes shall be as defined in ISO 857-1 and listed in 4.2.

Each test usually qualifies only one welding process. A change of welding process requires a new qualification test. However, it is permitted for a welder to be qualified for two or more welding processes by welding a single test piece (multi process joint) or by two or more separate qualification tests. The ranges of qualification for each welding process used and for the multi processes joint for butt welds are given in Table 1.

For welding process 141 a change in current from direct current to alternating current and vice versa requires a new qualification test.

Table 1 — Thickness range for single and multi process joints for butt welds

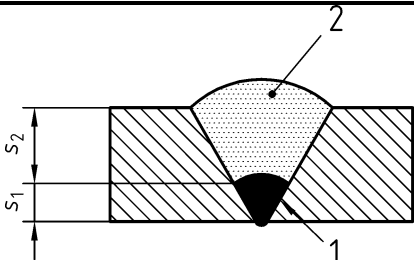
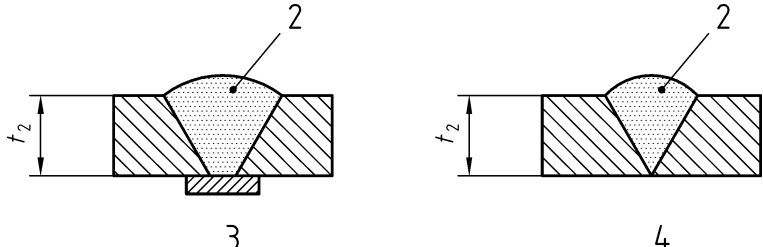
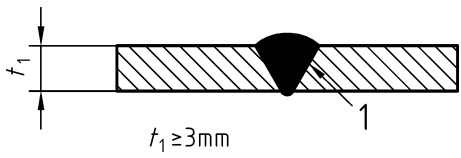
Welding process used for the test piece	Thickness range	
	Single process joint	Multi process joint
 <p>Key</p> <p>1 Welding process 1 2 Welding process 2</p>	<p>according to Table 3 for welding process 1: $t = s_1$ for welding process 2: $t = s_2$</p>	<p>according to Table 3 with $t = s_1 + s_2$</p>
 <p>Key</p> <p>2 Welding process 2 3 Welding with backing (mb) 4 Welding without backing (nb)</p>	<p>according to Table 3 for welding process 1: $t = t_1$ for welding process 2: $t = t_2$</p>	<p>according to Table 3 $t = t_1 + t_2$ Welding process 1 only for welding of the root area</p>
 <p>Key</p> <p>1 Welding process 1</p>		

5.3 Product type

The qualification test shall be carried out on plate or pipe. The following criteria are applicable:

- a) welds in pipes, outside pipe diameter $D > 25$ mm, qualify welds in plates;
- b) welds in plates qualify welds in pipe:
 - of outside pipe diameter $D \geq 150$ mm, for welding positions PA, PB and PC;
 - of outside pipe diameter $D \geq 500$ mm, for all other welding positions.

5.4 Type of weld

The qualification test shall be carried out as butt or fillet weld. The following criteria are applicable:

- a) butt welds qualify butt welds in any type of joint except branch connections (see also 5.4 c));
- b) in cases where the majority of work is fillet welding, the welder shall also be qualified by an appropriate fillet welding test; in cases where the majority of work is butt welding, butt welds qualify fillet welds;
- c) butt welds in pipes without backing qualify branch connections with an angle $\geq 60^\circ$ and the same range of qualification as in Tables 1 to 7. For a branch weld the range of qualification is based on the outside pipe diameter of the branch;
- d) for applications where the type of weld cannot be qualified by means of either a butt or fillet weld test then a specific test piece should be used to qualify the welder, e.g. branch connection, finishing welding of castings, preheating.

NOTE For finishing welding of castings a test piece according to prEN ISO 15614-4:2003, Figures 1 and 2, may be applied.

5.5 Material groups

5.5.1 Aluminium and aluminium alloy groups of parent material

In order to reduce the number of qualification tests, aluminium and aluminium alloys with similar welding characteristics are grouped according to CR ISO 15608.

5.5.2 Range of qualification

The welding of any one parent material in a group confers qualification on the welder for the welding of all other parent material within the same group as well as other groups according to Table 2.

When welding parent materials outside the grouping system a separate test is required.

A test piece between materials of groups 21 to 23 with materials of groups 24 or 25 qualifies any dissimilar joint obtained from any combination between materials from groups 21 to 23 with materials from groups 24 or 25. Any dissimilar joint with the material of group 26 requires a specific qualification test.

Table 2 — Range of qualification for parent material

Material group ^a of the test piece	Range of qualification					
	21	22	23	24	25	26
21	X	X	—	—	—	—
22	X	X	—	—	—	—
23	X	X	X ^b	—	—	—
24	—	—	—	X	X	—
25	—	—	—	X	X	—
26	—	—	—	X	X	X

^a Material group according to CR ISO 15608.

^b See also 5.6.

Key

X indicates those material groups for which the welder is qualified.

— indicates those material groups for which the welder is not qualified.

5.6 Welding consumables

Qualification with filler metal, e.g. with welding processes 141 and 15, qualifies for welding without filler metal but not vice versa.

Qualification with AlMg alloy type filler metals qualifies the use of AlSi alloy types but not vice versa.

For welding process 131 an increase of the Helium content of the shielding gas greater than 50 % requires a new qualification test.

5.7 Dimensions

The welder qualification test of butt welds is based on the material thickness and outside pipe diameters. The ranges of qualification are specified in Tables 3 and 4.

NOTE It is not intended that material thickness or outside pipe diameters should be measured precisely but rather the general philosophy behind the values given in Tables 3 and 4 should be applied.

For fillet welds the range of qualification for material thickness is specified in Table 5.

In the case of branch welding the material thickness criteria to which Table 3 applies and the outside pipe diameter criteria to which Table 4 applies is as follows:

- Set on: The material thickness and outside pipe diameter of the branch;
- Set in or set through: The material thickness of the main pipe or shell and the outside pipe diameter of the branch.

For test pieces of different outside pipe diameters and material thicknesses, the welder is qualified for:

- 1) the thinnest and thickest material thickness qualified in accordance with Table 3.
- 2) the smallest and largest outside pipe diameter qualified in accordance with Table 4;

Table 3 — Range of qualification of material thickness and weld metal thickness (multi process) of test piece for butt welds

Dimension in millimetres

Material thickness of test piece <i>t</i>	Range of qualification
$t \leq 6$	0,5 <i>t</i> to 2 <i>t</i>
$t > 6$	≥ 6

Table 4 — Range of qualification for outside pipe diameter

Dimension in millimetres

Outside pipe diameter of test piece ^a <i>D</i>	Range of qualification
$D \leq 25$	<i>D</i> to 2 <i>D</i>
$D > 25$	$\geq 0,5 D$ (25 mm min.)
^a For structural hollow sections, <i>D</i> is the dimension of the smaller side.	

Table 5 — Range of qualification of material thickness of test piece for fillet welds^a

Dimension in millimetres

Material thickness of test piece <i>t</i>	Range of qualification
$t < 3$	<i>t</i> to 3
$t \geq 3$	≥ 3
^a See also Table 8.	

5.8 Welding positions

The range of qualification for each welding position is given in Table 6. The welding positions and symbols refer to EN ISO 6947.

The test pieces shall be welded in accordance with the nominal angles of the welding positions according to EN ISO 6947.

Qualification tests welded in position on plates qualify the same position on rotating pipes (see 5.3 b)).

The welding position H-L045 for pipes qualifies for all pipe angles.

Welding two pipes with the same outside pipe diameter, one in welding position PF and one in welding position PC, also qualifies the range of qualification of a pipe welded in welding position H-L045.

Outside pipe diameters $D \geq 150$ mm can be welded in two welding positions (PF 2/3 of circumference, PC 1/3 of circumference) using one test piece in a fixed position.

Table 6 — Range of qualification for welding positions

Welding position of test piece	Range of qualification ^a									
	PA	PB ^b	PC	PD ^b	PE	PF (Plate)	PF (Pipe)	PG (Plate)	PG (Pipe)	H-L045
PA	X	X	–	–	–	–	–	–	–	–
PB ^b	X	X	–	–	–	–	–	–	–	–
PC	X	X	X	–	–	–	–	–	–	–
PD ^b	X	X	X	X	X	X	–	–	–	–
PE	X	X	X	X	X	X	–	–	–	–
PF (Plate)	X	X	–	–	–	X	–	–	–	–
PF (Pipe)	X	X	–	X	X	X	X	–	–	–
PG (Plate)	–	–	–	–	–	–	–	X	–	–
PG (Pipe)	X	X	–	X	X	–	–	X	X	–
H-L045	X	X	X	X	X	X	X	–	–	X

^a Additionally the requirements of 5.3 and 5.4 shall be observed.

^b Welding position PB and PD are only used for fillet welds (see 5.4 b) and can only qualify fillet welds in other welding positions.

Key

X indicates those welding positions for which the welder is qualified

– indicates those welding positions for which the welder is not qualified

5.9 Weld details

Depending on the weld details, the ranges of qualification are shown in Tables 7 and 8.

Table 7 — Range of qualification for weld details on butt welds

Weld details of test piece	Range of qualification		
	single-side welding / welding without backing (ss nb)	single-side welding / welding with backing (ss mb)	welding from both sides (bs)
single-side welding /welding without backing (ss nb)	X	X	X
single-side welding /welding with backing (ss mb)	–	X	X
welding from both sides (bs)	–	X	X

Key

X indicates those welds for which the welder is qualified

– indicates those welds for which the welder is not qualified

Table 8 — Range of qualification of layer technique for fillet welds

Test piece ^a	Range of qualification	
	single layer (sl)	multi layer (ml)
single layer (sl)	X	—
multi layer (ml)	X	X

^a Throat thickness shall be in the range of $0,5 t \leq a \leq 0,7 t$.

Key

X indicates the layer technique for which the welder is qualified

— indicates the layer technique for which the welder is not qualified

6 Examination and testing

6.1 Supervision

The welding and testing of test pieces shall be witnessed by the examiner or examining body.

The test pieces shall be marked with the identification of the examiner and the welder before welding starts. Additionally welding positions for all test pieces are to be marked on the test piece and for fixed pipe welds, the 12 o'clock welding position shall also be marked.

The examiner or examining body may stop the test if the welding conditions are not correct or if it appears that the welder does not have the skill to fulfil the requirements, e.g. where there are excessive and/or systematic repairs.

6.2 Shapes, dimensions and numbers of test pieces

The shape and dimension of test pieces (see 5.7) required are shown in Figures 1 to 4.

For pipes a minimum examination length of 150 mm is required. However, if the circumference of pipes is less than 150 mm additional test pieces will be required with a maximum of three test pieces.

Dimensions in millimetres

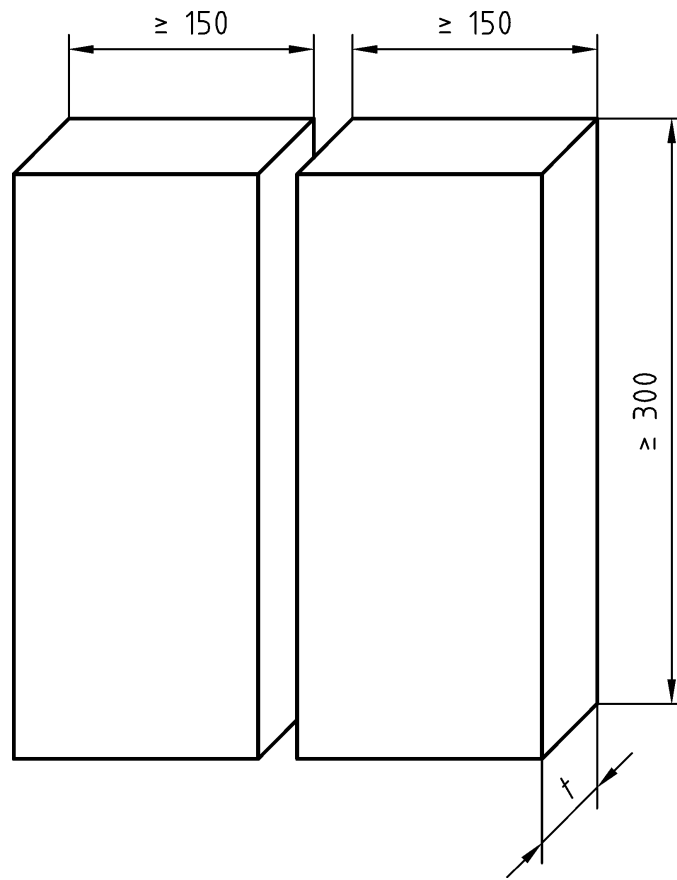

Key

t Material thickness of test piece

Figure 1 — Dimensions of test piece for a butt weld in plate

Dimensions in millimetres

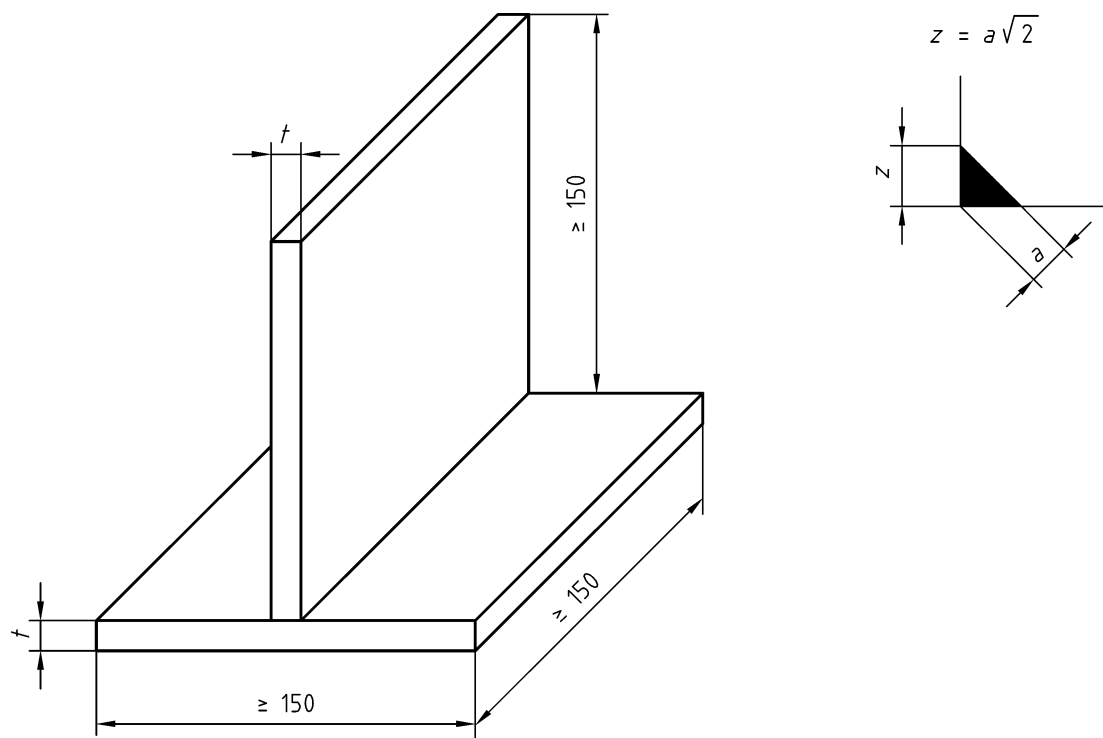

$$0,5 t \leq a \leq t$$

Key

- a* Design throat thickness
- t* Material thickness of test piece
- z* Leg length of fillet weld

Figure 2 — Dimensions of test piece for a fillet weld on plate

Dimensions in millimetres

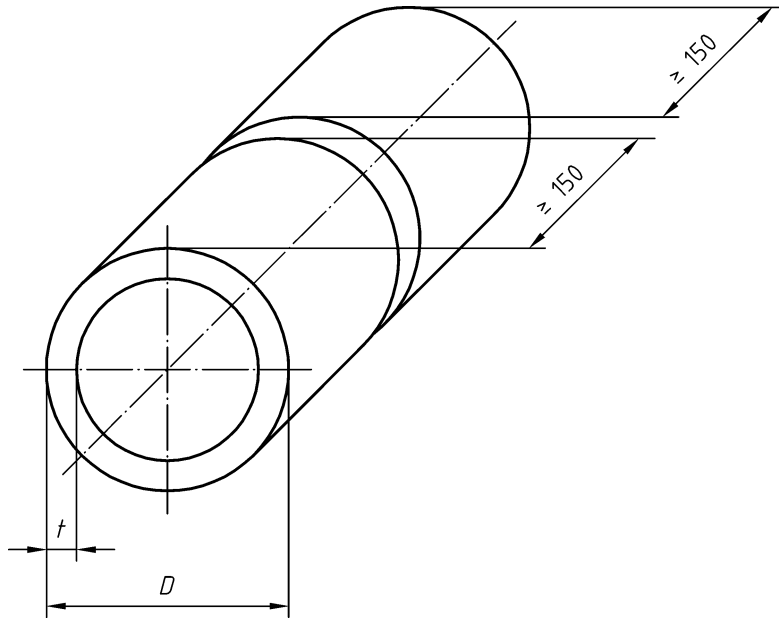

Key

- D Outside pipe diameter
- t Material thickness of test piece (wall thickness)

Figure 3 — Dimensions of test piece for a butt weld in pipe

Dimensions in millimetres

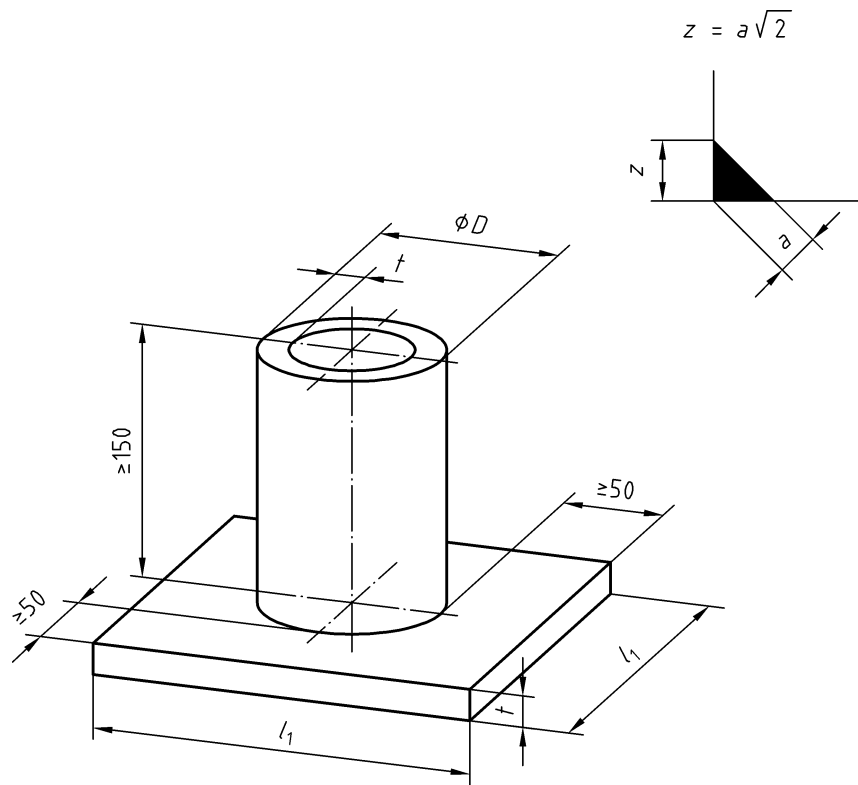

t corresponds to the thinner part

$$0,5 t \leq a \leq t$$

Key

- a Design throat thickness
- D Outside pipe diameter
- l_1 Length of test piece
- t Material thickness of test piece (plate or wall thickness)
- z Leg length of fillet weld

Figure 4 — Dimensions of test piece for a fillet weld on pipe

6.3 Welding conditions

Welding shall be in accordance with a pWPS or WPS in accordance with EN ISO 15609-1.

The following welding conditions shall apply:

- a) the welding time for the test piece shall correspond to the working time under usual production conditions;
- b) the test pieces shall have at least one stop and one re-start in the root run and in the capping run and be identified in length to be examined;
- c) any post-welded heat treatment required in the pWPS or WPS can be omitted unless bend or tensile tests are required;
- d) identification of the test piece;

- e) the welder may, only with the permission of the examiner or examining body, remove minor imperfections by grinding, except on the surfaces after finishing the weld.

6.4 Test methods

Each completed weld shall be tested according to Table 9 in the as-welded condition.

If the weld is accepted by visual testing, the additional test(s) according to Table 9 shall be carried out.

When permanent backing was used in the qualification test it shall be removed prior to destructive testing.

The test specimen for macroscopic examination shall be prepared and etched on one side to clearly reveal the weld. Polishing is not required.

When radiographic testing of butt welds made by welding process 131 is undertaken it shall be supplemented by either two additional bend tests (one face and one root or two side bends) or two fracture tests (one face and one root).

Table 9 — Test methods

Test method	Butt weld (in plate or pipe)	Fillet weld and branch connection
Visual testing according to EN 970	mandatory	mandatory
Radiographic testing according to EN 1435	mandatory ^{a b}	not mandatory
Bend test according to EN 910	mandatory ^{a b e}	not applicable
Fracture test according to EN 1320	mandatory ^{a b e}	mandatory ^{c d}

^a Except process 131, either radiographic testing or bend or fracture tests shall be used.

^b When radiographic testing is used, then additional bend or fracture tests are mandatory for welding process 131.

^c The fracture tests may be replaced by a macroscopic examination according to EN 1321 of at least two sections.

^d The fracture tests on pipes may be replaced by radiographic testing.

^e For outside pipe diameter $D \leq 25$ mm, the bend or fracture tests may be replaced by a notched tensile test of the complete test piece (example is given in Figure 8).

6.5 Test piece and test specimen

6.5.1 General

In 6.5.2 to 6.5.4 details of the type, dimensions and preparation of the test pieces and test specimens are given. In addition, the requirements for destructive tests are indicated.

6.5.2 Butt weld in plate and pipe

When radiographic testing is used, the examination length of the weld (see Figures 5a), 7a) and 7b)) in the test piece shall be radiographed in the as-welded condition (no removal of excess weld metal).

When fracture testing is used, the test piece examination length shall be cut into the test specimens of equal width and all of them tested in such a manner that the fracture will be reached. The examination length of each test specimen shall be ≥ 40 mm (see Figure 5b)). All notch profiles according to EN 1320 are permitted.

When transverse bend testing in accordance with EN 910 is used, two root bend test specimens and two face bend test specimens shall be tested in accordance with EN ISO 15614-2.

When only transverse bend testing is carried out, the examination length shall be cut into test specimens of equal width and all of them shall be tested. When only side bend tests are used, a minimum of four test specimens shall be taken equally spaced along the examination length. One of these side bend tests shall be taken from the start and stop area in the examination length. Bend tests shall be performed in accordance with EN 910.

For $t > 12$ mm, the transverse bend tests can be substituted by side bend tests.

For pipes, the number of additional fracture or transverse bend test specimens to welding process 131, using radiographic testing, depends on the welding position. For welding position PA or PC one root and one face bend test specimen shall be tested (see Figure 7a)). For all other welding positions, two root and two face bend test specimens shall be tested (see Figure 7b)).

Dimensions in millimetres

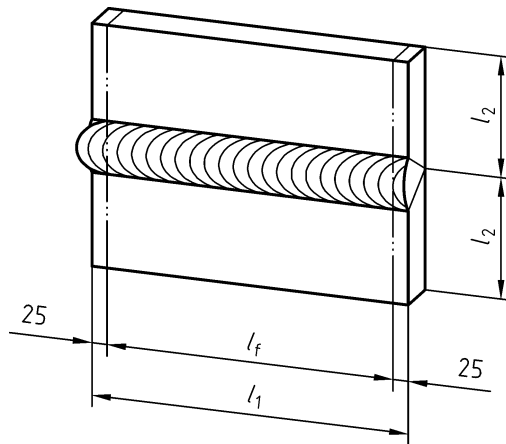

Key

- l_1 Length of test piece
- l_2 Half width of test piece
- l_f Examination length

a) Sectioning into an even-numbered quantity of test specimens

Dimensions in millimetres

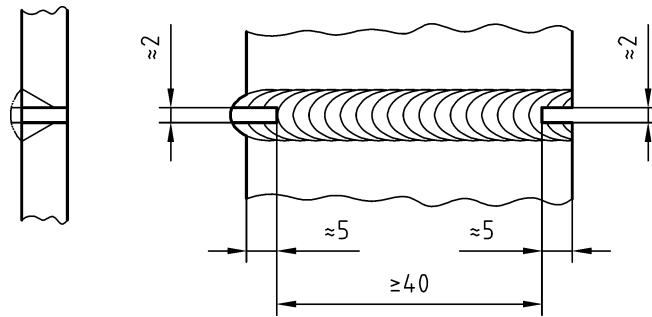

b) Examination length of the test specimen

NOTE In addition, the test specimen may be longitudinally notched in the centre of the weld of the tension side in order to achieve a fracture in the weld of the test specimen.

Figure 5 — Preparation and fracture testing of test specimens for a butt weld in plate

6.5.3 Fillet weld on plate

For fracture tests (see Figure 6) the test piece can be cut, if necessary, into several test specimens. Each test specimen shall be positioned for breaking in accordance with EN 1320 and examined after fracture.

When macroscopic examination is used, at least two test specimens shall be taken. One macroscopic specimen shall be taken at the stop/start location.

Dimensions in millimetres

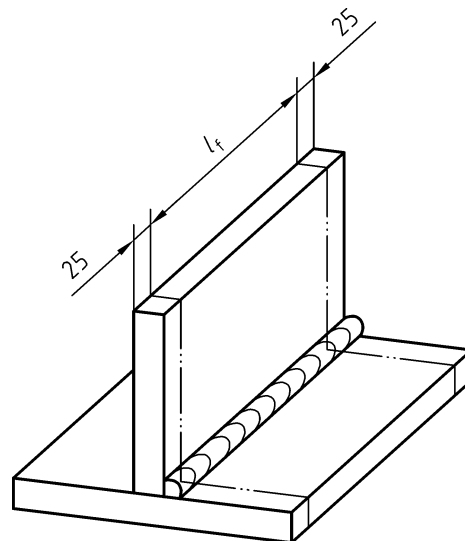

Key

l_f Examination length

Figure 6 — Examination length for fracture testing for a fillet weld on plate

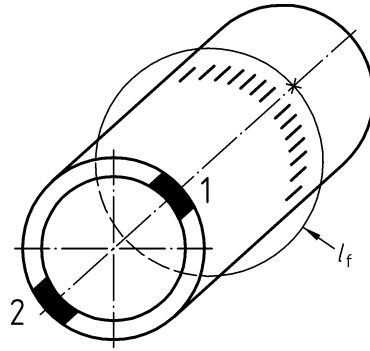

Key

- l_f Examination length
- 1 Location for one root fracture or one root transverse bend or one side bend test specimen
- 2 Location for one face fracture or one face transverse bend or one side bend test specimen

a) Sectioning of additional fracture or bend test specimens for welding positions PA and PC

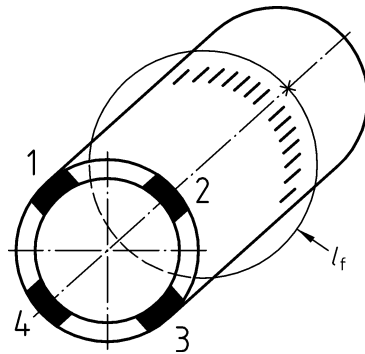

Key

- l_f Examination length
- 1 One root fracture or one root transverse bend or one side bend test specimen
- 2 One face fracture or one face transverse bend or one side bend test specimen
- 3 One root fracture or one root transverse bend or one side bend test specimen
- 4 One face fracture or one face transverse bend or one side bend test specimen

b) Sectioning of additional fracture or bend test specimens for welding positions PF, PG, H-L045

Dimensions in millimetres

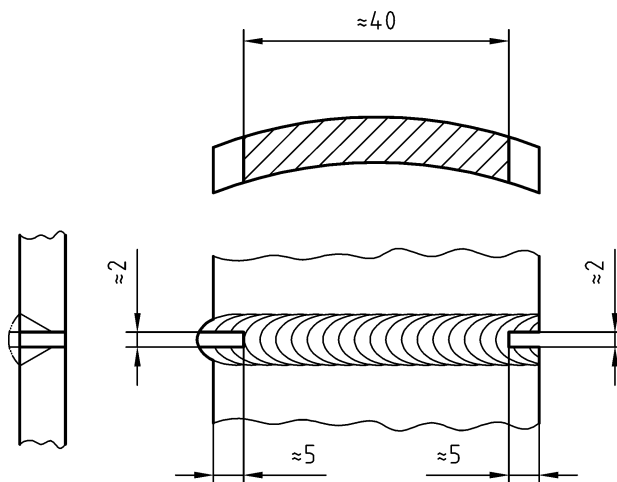

c) Examination length of the fracture test specimen

NOTE In addition, the test specimen may be longitudinally notched in the centre of the weld of the tension side in order to achieve a fracture in the weld of the test specimen.

Figure 7 — Preparation and locations of test specimens for a butt weld in pipe

Dimensions in millimetres

For $t \geq 1,8$ mm: $d = 4,5$ mm
 For $t < 1,8$ mm: $d = 3,5$ mm

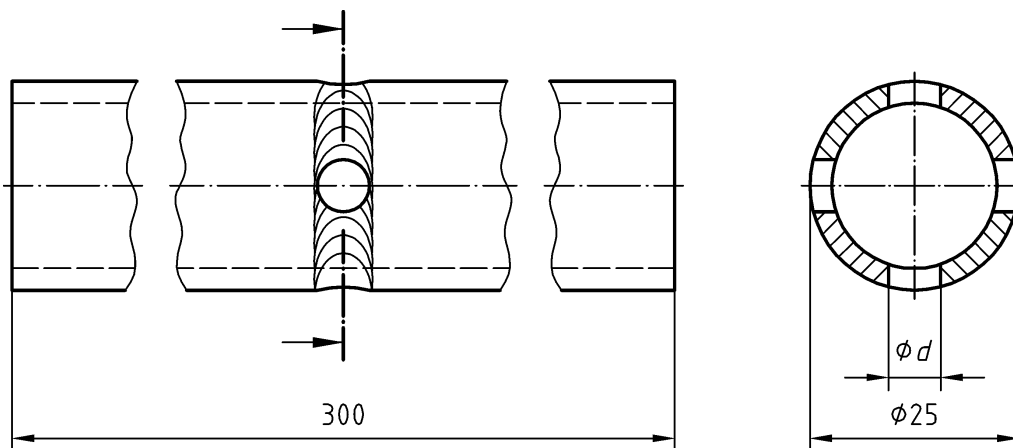

Holes are not allowed in start and stop areas.

NOTE Notch profiles s and q are also permitted in circumferential direction according to EN 1320.

Figure 8 — Example for notch tensile test for pipe test piece outside diameter ≤ 25 mm

6.5.4 Fillet weld on pipe

For fracture tests, the test piece shall be cut into four or more test specimens and fractured (one possibility is shown in Figure 9).

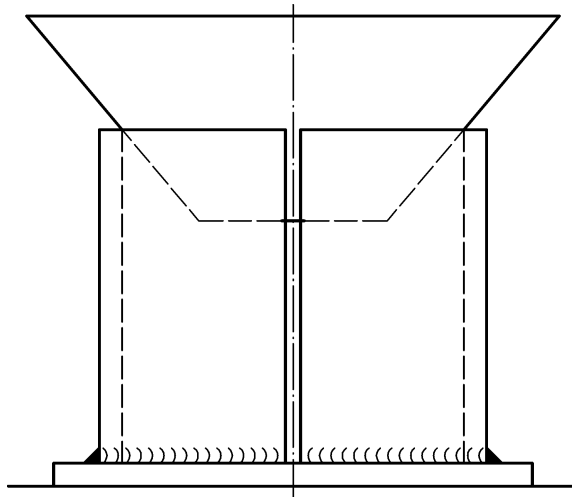

Figure 9 — Preparation and fracture testing of test specimens for a fillet weld on pipe

When macroscopic examination is used, at least two test specimens shall be taken. One macroscopic specimen shall be taken at the stop/start location.

6.6 Test record

The results of all testing shall be documented.

7 Acceptance requirements for test pieces

Test pieces shall be evaluated according to the acceptance requirements specified for relevant types of imperfections.

Prior to any testing the following shall be checked:

- all spatter has been removed;
- no grinding has been performed on the root and the face side of the weld (according to 6.3);
- the stop and restart in the root run and in the capping run are identified (according to 6.3);
- the profile and dimensions are acceptable.

The acceptance requirements for imperfections found by test methods according to this document shall, unless otherwise specified, be assessed in accordance with EN 30042. A welder is qualified if the imperfections are within quality level B in EN 30042, except for imperfections types as follows; excess weld metal, excessive convexity, excessive throat thickness and excessive penetration, for which level C shall apply.

Bend test specimens shall not reveal any one single flaw > 3 mm in any direction. Flaws appearing at the edges of a test specimen during testing shall be ignored in the evaluation unless there is evidence that cracking is due to incomplete penetration, slag or other flaw.

If the imperfections in the welder's test piece exceed the permitted maximum specified, then the welder fails the test.

Reference should also be made to the corresponding acceptance criteria for non-destructive testing. Specified procedures shall be used for all destructive and non-destructive testing.

NOTE The correlation between the quality levels of EN 30042 and the acceptance levels of the different non-destructive testing techniques are given in EN 12062.

8 Re-tests

If any test fails to comply with the requirements of this document, the welder shall be given the opportunity to repeat the qualification test.

If it is established that failure is due to metallurgical or other extraneous causes that cannot be directly attributed to the welder's lack of skill, an additional test is required in order to assess the quality and integrity of the new test material and/or new test conditions.

9 Period of validity

9.1 Initial qualification

The welder's qualification is valid from the date of welding of the test pieces, providing that the required tests have been carried out and acceptable test results are available.

9.2 Confirmation of the validity

The welder's qualification test certificate issued is valid for a period of two years. This is providing that the welding coordinator or the responsible personnel of the employer can confirm that the welder has been working within the initial range of qualification. This shall be confirmed every six months.

9.3 Prolongation of qualification

Welder's qualification test certificates according to this document can be prolonged every two years by an examiner/examining body.

Before prolongation of the certification takes place, 9.2 needs to be satisfied and also the following conditions need to be confirmed:

- a) All records and evidence used to support prolongation are traceable to the welder and identifies the WPS(s) that have been used in production;
- b) Evidence used to support prolongation shall be of a volumetric nature (radiographic testing or ultrasonic testing) or for destructive testing (fracture or bends) made on two welds during the previous six months. Evidence relating to prolongation needs to be retained for a minimum of two years;
- c) The welds satisfy the acceptance levels for imperfections as specified in Clause 7;
- d) The test results mentioned in 9.3 b) shall demonstrate that the welder has reproduced the original test conditions.

NOTE Examples for variables to be confirmed and traceable see Annex D.

10 Certificate

It shall be verified that the welder has successfully passed the qualification test. All essential variables shall be recorded on the certificate. If the test piece(s) fail(s) any of the required tests, no certificate shall be issued.

The certificate shall be issued under the sole responsibility of the examiner or examining body and shall contain all information detailed in Annex A. The format of this annex A is recommended to be used as the welder's qualification test certificate. If any other form of welder's qualification test certificate is used, it shall contain the information required in Annex A.

In general for each test piece a separate welder's qualification test certificate shall be issued.

If more than one test piece is welded a single welder's qualification test certificate can be issued that combines the ranges of qualification of the individual test pieces. Only one of the following essential variables is permitted to be changed, except the samples given in 5.7:

- type of weld;
- welding position;
- material thickness.

It shall be ensured that the welder's qualification test certificate cannot lead to ambiguity. Therefore, it is recommended to issue the welder's qualification test certificate in at least one of the languages English, French or German in combination with any other language, if necessary.

The practical test and the examination of job knowledge (see Annex A) shall be designated by "Accepted" or "Not tested".

Each change of the essential variables for the qualification test beyond the permitted ranges requires a new test and a new welder's qualification test certificate.

11 Designation

The designation of a welder qualification shall comprise the following items in the order given (the system is arranged so that it can be used for computerization):

- a) the number of this document, EN ISO 9606-2;
- b) the essential variables:
 - 1) welding processes: refer to 4.2, 5.2 and EN ISO 4063;
 - 2) product type: plate (P), pipe (T), refer to 4.3.1 and 5.3;
 - 3) type of weld: butt weld (BW), fillet weld (FW), refer to 5.4;
 - 4) material group: refer to 5.5;
 - 5) welding consumables: refer to 5.6;
 - 6) dimensions of test piece: material thickness t and outside pipe diameter D , refer to 5.7;
 - 7) welding positions: refer to 5.8 and EN ISO 6947;
 - 8) weld details: refer to 5.9.

The type of shielding and backing gas shall not be incorporated in the designation but shall be included in the welder's qualification test certificate (see EN ISO 15609-1:2004, Annex A).

Designation examples are shown in Annex B.

Annex A
(informative)

Welder's qualification test certificate

Designation(s):

WPS – Reference:

Examiner or examining body – Reference No.:

Welder's Name:
 Identification:
 Method of identification:
 Date and place of birth:
 Employer:
 Code/Testing Standard:

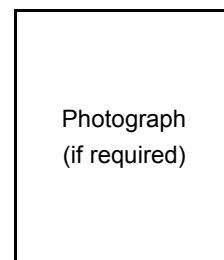

Job knowledge: Acceptable/Not tested (Delete as necessary)

	Test piece	Range of qualification
Welding process(es)		
Product type (plate or pipe)		
Type of weld		
Material group(s)		
Welding consumable (Designation)		
Shielding gas		-----
Auxiliaries (e.g. backing gas)		-----
Material thickness (mm)		
Outside pipe diameter (mm)		
Welding position		
Weld details		

Type of tests	Performed and accepted	Not tested	Name of examiner or examining body: Place, date and signature of examiner or examining body: Date of welding: Validity of qualification until:
Visual testing			
Radiographic testing			
Fracture test			
Bend test			
Notch tensile test			
Macroscopic examination			

Confirmation of the validity by employer/welding coordinator for the following 6 month (refer to 9.2)

Date	Signature	Position or title

Prolongation for qualification by examiner or examining body for the following 2 years (refer to 9.3)

Date	Signature	Position or title

Annex B (informative)

Designation examples

B.1 Example 1

Welder qualification **EN ISO 9606-2 131 P FW 22 S t10 PB sl**

Explanation			Range of qualification
131	Welding process	MIG-Welding	131
P	Plate		P T: $D \geq 150$ mm
FW	Fillet weld		FW
22	Material group according to CR ISO/TR 15608	Material group 22: Non heat treatable alloys	21, 22
S	Welding consumable	solid wire	S
t10	Material thickness of test piece	Material thickness: 10 mm	≥ 3 mm
PB	Welding position	fillet welding position, horizontal - vertical	PA, PB
sl	Weld details	single layer	sl

B.2 Example 2

Welder qualification **EN ISO 9606-2 131 P BW 23 S t15 PA ss mb**

Explanation			Range of qualification
131	Welding process	MIG-Welding	131
P	Plate	–	P T: $D \geq 150$ mm
BW	Butt weld	–	BW, FW (see 5.4 b)
23	Material group according to CR ISO/TR 15608	Material group 23: Heat treatable alloys	21, 22, 23
S	Welding consumable	solid wire	S
t15	Material thickness of test piece	Material thickness: 15 mm	≥ 6 mm
PA	Welding position	butt welding position, flat	PA, PB
ss mb	Weld details	single-side welding with material backing multi layer	ss mb, bs For FW: sl, ml

B.3 Example 3

Welder qualification EN ISO 9606-2 141 T BW 23 S t03 D150 PF ss nb

Explanation			Range of qualification
141	Welding process	TIG-Welding	141
T	Tube	–	T P
BW	Butt weld	–	BW, FW (see 5.4 b)
23	Material group according to CR ISO 15608	Material group 23: Heat treatable alloys	21, 22, 23
S	Welding consumable	solid rod	S
t3	Material thickness of test piece	Material thickness: 3 mm	1,5 mm to 6 mm
D150	Outside pipe diameter of test piece	Outside pipe diameter: 150 mm	≥ 75 mm
PF	Welding position	butt weld on pipe, pipe fixed, axis horizontal	PA, PB, PD, PE, PF
ss nb	Weld details	single-side welding, no backing single layer	ss nb, ss mb, bs For FW: sl

B.4 Example 4

Welder qualification EN ISO 9606-2 131 P BW 22 S t13 PA ss nb

Welder qualification EN ISO 9606-2 131 P FW 22 S t13 PB ml

Explanation			Range of qualification
131	Welding process	MIG-welding	131
P	Plate	–	P T: $D \geq 150$ mm
BW	Butt weld	–	BW, FW
FW	Fillet weld		
22	Material group according to CR ISO 15608	Material group 22: Non heat treatable alloys	21, 22
S	Welding consumable	solid wire	S
t13	Material thickness of test piece	Material thickness: 13 mm	≥ 6 mm
PA	Welding position	butt weld, flat	PA, PB
PB		fillet weld, horizontal-vertical	
ss nb	Weld details	single-side welding, no backing multi layer	ss nb, ss mb, bs For FW: sl, ml

B.5 Example 5

Welder qualification EN ISO 9606-2 141/131 T BW 22 S t15(5/10) D200 PA ss nb

Explanation			Range of qualification
141 131	Welding process	TIG-Welding, root area (2 layers) MIG-Welding, filling runs	141 131
T	Tube	–	T P
BW	Butt weld	–	BW, FW (see 5.4 b)
22	Material group according to CR ISO 15608	Material group 22: Non heat treatable alloys	21, 22
S	Welding consumable	solid rod/wire	S
t15	Material thickness of test piece	Material thickness 15 mm 141: $s_1 = 5$ mm 131: $s_2 = 10$ mm	141: 2,5 mm to 10 mm 131: ≥ 6 mm
D200	Outside pipe diameter of test piece	Outside pipe diameter: 200 mm	≥ 100 mm
PA	Welding position	butt weld on pipe, pipe rotating, axis horizontal	PA, PB
ss nb	Weld details	single-side welding, no backing multi layer	141: ss nb, ss mb, bs 131: ss mb, bs For FW: sl, ml

B.6 Example 6

Welder qualification EN ISO 9606-2 141 T BW 21 S t3 D30 PF ss nb

Welder qualification EN ISO 9606-2 141 T BW 21 S t10 D150 PF ss nb

Explanation			Range of qualification
141	Welding process	TIG-welding	141
T	Tube	–	P T
BW	Butt weld	–	BW, FW (see 5.4 b)
21	Material group according to CR ISO 15608	Material group 21: Pure aluminium	21, 22
S	Welding consumable	solid rod	S
t3/t10	Material thickness of test piece	Material thickness: 3 mm/13 mm	$\geq 1,5$ mm
D30/D150	Outside pipe diameter of test piece	Outside pipe diameter: 30 mm/150 mm	≥ 25 mm
PF	Welding position	butt weld on pipe, pipe fixed, axis horizontal	PA, PB, PD, PE, PF
ss nb	Weld details	single-side welding, no backing single/multi layer	ss nb, ss mb, bs For FW: sl, ml

B.7 Example 7

Welder qualification EN ISO 9606-2 141 T BW 22 S t8 D100 PF ss nb

Welder qualification EN ISO 9606-2 141 T BW 22 S t8 D100 PC ss nb

Explanation			Range of qualification
141	Welding process	TIG-Welding	141
T	Tube	–	T P
BW	Butt weld	–	BW, FW (see 5.4 b)
22	Material group according to CR ISO 15608	Material group 22: Non heat treatable alloys	21, 22
S	Welding consumable	solid rod	S
t8	Material thickness of test piece	Material thickness: 8 mm	≥ 6 mm
D100	Outside pipe diameter of test piece	Outside pipe diameter: 100 mm	≥ 50 mm
PF PC	Welding position	butt weld on pipe, axis horizontal fix and vertical	all, except PG
ss nb	Weld details	single-side welding, no backing multi layer	ss nb, ss mb, bs For FW: sl, ml

Annex C **(informative)**

Job knowledge

C.1 General

The test of job knowledge is recommended, but it is not mandatory.

However, some countries may require that the welder undergoes a test of job knowledge. If the job knowledge test is carried out, it should be recorded on the welder's qualification test certificate.

This annex outlines the job knowledge that a welder should have to ensure that procedures are followed and common practices are complied with. The job knowledge indicated in this annex is only pitched at the most basic level.

Owing to different training programmes in various countries, it is only proposed to standardize general objectives or categories of job knowledge. The actual question used should be drawn up by the individual country, but should include questions on areas covered in C.2, relevant to the qualification test of welders.

The actual tests of a welder's job knowledge may be given by any of the following methods or combinations of these methods:

- a) written objective tests (multiple choice);
- b) oral questioning following a set of written questions;
- c) computer testing;
- d) demonstration/observation testing following a written set of criteria.

The test of job knowledge is limited to the matters related to the welding process used in the test.

C.2 Requirements

C.2.1 Welding equipment

- a) Identification and assembly of essential components and equipment;
- b) Type of welding current;
- c) Correct connection of the welding return cable.

C.2.2 Welding processes

- a) Types and size of electrodes;
- b) Identification of shielding gas and flow rate;
- c) Type, size and maintenance of nozzles/contact tip;
- d) Protection of the welding arc from draughts;

- e) Selection and limitation of the transfer modes.

C.2.3 Parent materials

- a) Identification of material;
- b) Methods and control of pre-heating;
- c) Control of interpass temperature.

C.2.4 Welding consumables

- a) Identification of welding consumables;
- b) Storage, handling and conditions of welding consumables;
- c) Selection of correct size;
- d) Cleanliness of electrodes and filler wires;
- e) Control of wire spooling;
- f) Control and monitoring of gas flow rates and quality.

C.2.5 Safety precautions

- a) Safe assembly, setting up and turn off procedures;
- b) Safe control of welding fumes and gases;
- c) Personal protection;
- d) Fire hazards;
- e) Welding in confined spaces;
- f) Awareness of welding environment;
- g) Environment of increase hazard electric shock;
- h) Radiation from the arc;
- i) Effects of stray arcing;
- j) Safe storage, handling and use of compressed gases;
- k) Leak detection on gas hoses and fittings.

C.2.6 Welding sequences/procedures

Appreciation of welding procedure requirements and the influence of welding parameters.

C.2.7 Joint preparation and weld representation

- a) Conformance of joint preparation to the welding procedure specification (WPS);
- b) Cleanliness of fusion faces.

C.2.8 Weld imperfections

- a) Identification of imperfections;
- b) Causes;
- c) Prevention and remedial action.

C.2.9 Welder qualification

The welder should be aware of the range of the qualification.

Annex D (informative)

Variables to be confirmed and traceable for prolongation

In order to prolong a welder's qualification test certificate, it should be confirmed that the welder has done welding representative of the original qualification test with regards to the variables given in Table D.1.

Table D.1 —Variables to be confirmed and traceable for prolongation

Variables	to be confirmed
Welding process(es)	X
Product type (pipe, plate, branch)	X
Type of weld	X
Material group	X
Welding consumables (designation)	X
Material thickness ^a	X
Outside pipe diameter ^b	X
Welding position	X
Weld details	X
^a Material thickness can vary $\pm 50\%$ from the initial test piece. ^b Outside pipe diameter can vary $\pm 50\%$ from the initial test piece.	

Annex ZA (normative)

Normative references to International publications with their corresponding European publications

The following referenced documents are indispensable for the application of this document. For dated references, only the edition cited applies. For undated references, the latest edition of the referenced document (including any amendments) applies.

Publication	Year	Title	EN	Year
ISO 2553		Welded, brazed and soldered joints – Symbolic representation on drawings.	EN 22553	
ISO 5173		Destructive tests on welds in metallic materials — Bend test (Revision of ISO 5173:1981 and ISO 5177:1981).	EN 910	
ISO 4063		Welding and allied processes – Nomenclature of processes and reference numbers.	EN ISO 4063	
ISO 6947		Welds – Working positions – Definitions of angles of slope and rotation.	EN ISO 6947	
ISO 9017		Destructive tests on welds in metallic materials — Fracture test.	EN 1320	
ISO 10042		Arc-welded joints in aluminium and its weldable alloys — Guidance on quality levels for imperfections.	EN 30042	
ISO 14732	1998	Welding personnel — Approval testing of welding operators for fusion welding and of resistance weld setters for fully mechanized and automatic welding of metallic materials	EN 1418	1997
ISO 15607	2003	Specification and qualification of welding procedures for metallic materials — General rules.	EN ISO 15607	2003
ISO 15609-1	2004	Specification and qualification of welding procedures for metallic materials — Welding procedure specification — Part 1: Arc welding.	EN ISO 15609-1	2004
ISO 15614-2		Specification and qualification of welding procedures for metallic materials — Welding procedure test — Part 2: Arc welding of aluminium and its alloys	EN ISO 15614-2	
ISO 17636		Non-destructive testing of welds — Radiographic testing of fusion-welded joints.	EN 1435	
ISO 17637		Non-destructive testing of welds — Visual testing of fusion-welded joints.	EN 970	
ISO 17639		Destructive tests on welds in metallic materials — Macroscopic and microscopic examination of welds.	EN 1321	

Bibliography

- [1] EN 12062, *Non-destructive examination of welds — General rules for metallic materials*.
- [2] CR ISO 15608, *Welding — Guidelines for a metallic material grouping system (ISO/TR 15608:2000)*.
- [3] prEN ISO 15614-4:2003, *Specification and qualification of welding procedures for metallic materials — Welding procedure test — Part 4: Finishing welding of aluminium castings (ISO/DIS 15614-4:2003)*.

ICS 26.160.01

Price based on 33 pages